

---

## Features

- Adjustable and Retriggerable Tracking Time
- Window Monitoring for Sensor Input
- Enable Input for Triggering
- Internal Noise Suppression (40 ms) and Retrigger Blocking (640 ms)
- Two- or Three-wire Applications

## Applications

- Motion Detectors
- Touch Sensors
- Timers

## 1. Description

The timer control circuit U2100B uses bipolar technology. It has different mode selections (zero voltage switch, phase control and relay control). The output stage is triggered according to input conditions. It can be used in triac application for two- or three-wire systems as a power switch.



---

## Timer Control for Triac and Relay

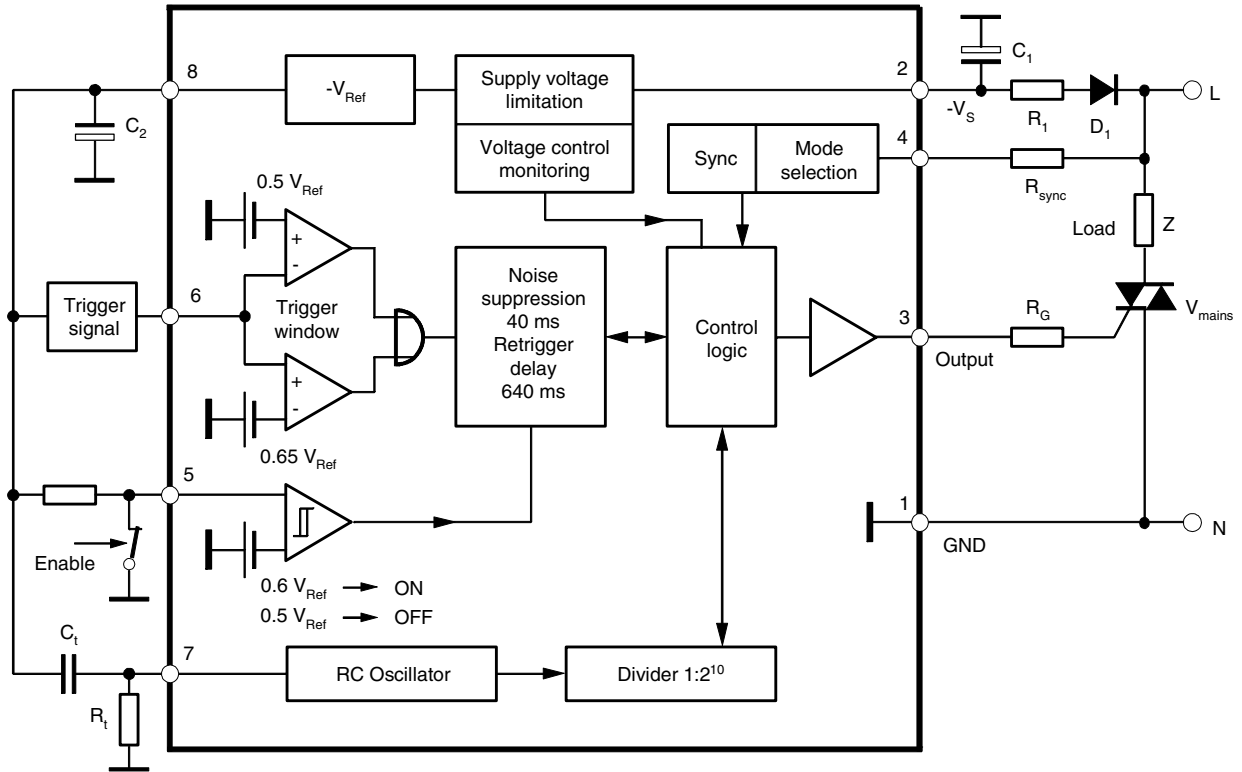
---

### U2100B

Rev. 4769C-INDCO-07/05

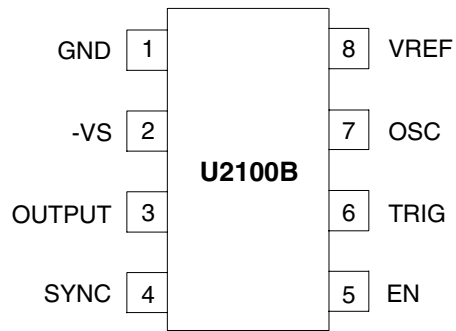


Figure 1-1. Block Diagram with External Circuit



## 2. Pin Configuration

**Figure 2-1.** Pinning DIP8/SO8



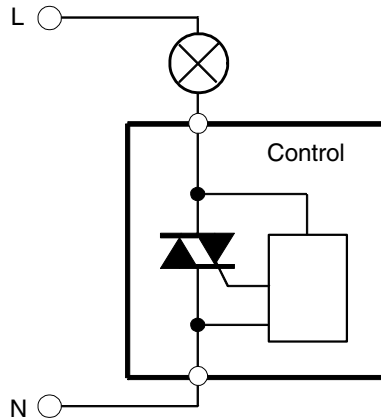
**Table 2-1.** Pin Description

Pin	Symbol	Function
1	GND	Reference point
2	-VS	Supply voltage
3	OUTPUT	Driver output
4	SYNC	Synchronization and mode selection
5	EN	Enable
6	TRIG	Input trigger signal
7	OSC	RC oscillator
8	VREF	Reference voltage

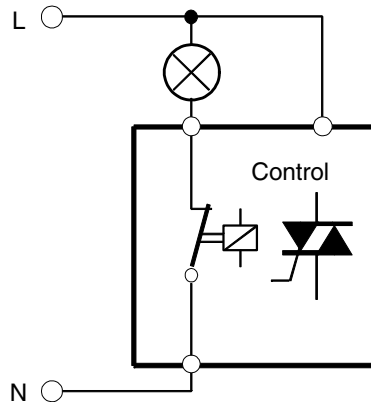
### 3. General Description

The monostable integrated power-control circuit U2100B can be used according to the mode selection in relay or triac applications. In addition, it can be used in triac applications for two-wire systems as power switch (the load in series to the switch), where the supply voltage for the control unit is gained from the remaining phase angle ( $\alpha_{\min}$  operation).

**Figure 3-1.** Two-wire Circuit



**Figure 3-2.** Three-wire Circuit



For three-wire switch systems, two operational modes are possible:

- Zero voltage switch operation for triac control
- Static operation for relay control

**3.1 Mode Selection Pin 4 and Supply Voltage Pin 2**

The operational modes can be selected by the external voltage at the synchronous input pin 4 (clamping). The mode selection determines the current requirement of the relay's or triac's driver stage and hence the selection of the supply voltage.

**3.2 Zero Voltage Switch Operation (Figure 3-3 on page 6)**

Selection condition:

$V_4$  = internal synchronous limitation, without external clamping

$$R_1 \approx 0.85 \frac{V_M - V_S}{2 I_{tot}}$$

$$I_{tot} = I_S + I_p + I_x$$

where:

- $I_S$  = Supply current of the IC without load
- $I_p$  = Average trigger current  $I_G$
- $I_x$  = External circuit current requirement
- $V_M$  = Mains voltage

Required firing pulse width  $t_p$

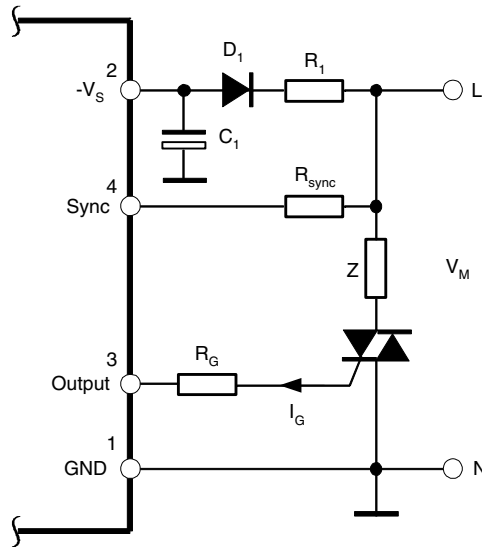
$$t_p = \frac{2}{\omega} \arcsin \left( \frac{I_L \times V_M}{P \times \sqrt{2}} \right)$$

where:

- $I_L$  = Triac latching current
- $P$  = Power at load Z

$$R_{sync}[k\Omega] \approx \frac{V_M[V] \times \sqrt{2} \sin(\omega \times t_p[s]) - 0.7}{1.8 \times 10^{-2}} - 176$$

**Figure 3-3.** Zero Voltage Switch Operation



### 3.3 DC Operation

Selection condition (Figure 3-4):

$+V_4 = 6.1V$ ,  $-V_4 =$  internal limitation where:

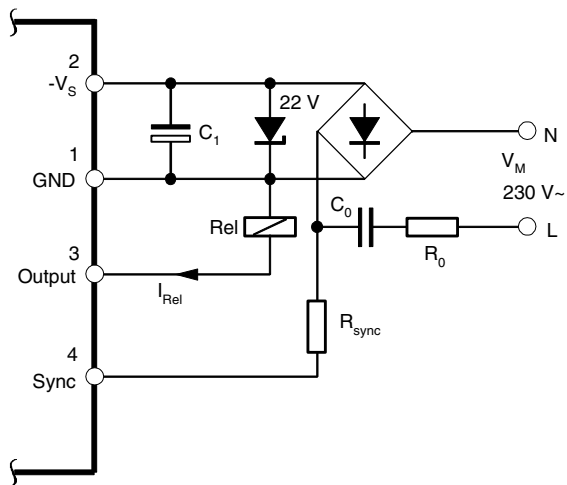
$$R_0 \approx 1/10 X_c$$

$$X_c = 0.85 \frac{V_M - V_S}{I_{tot}}$$

$$I_{tot} = I_S + I_{Rel} + I_X$$

$$C_0 = \frac{1}{\omega \times X_C}$$

**Figure 3-4.** DC Operation



### 3.4 $\alpha_{\min}$ Operation

Selection condition (Figure 3-5):

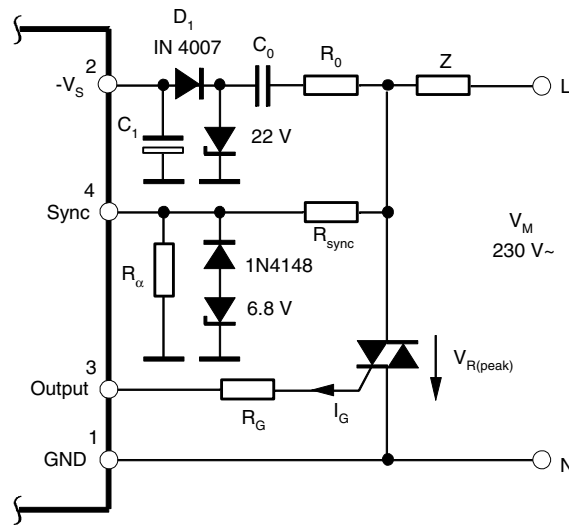
$$-V_4 = 6.5 \text{ to } 7.8\text{V}, +V_4 = \text{internal limitation}$$

$$R_{\alpha_{\max}} = R_{\text{sync}} \frac{3.6 \text{ V}}{V_{R(\text{peak})} - 3.6 \text{ V}}$$

$$R_{\alpha_{\min}} = R_{\text{sync}} \frac{10 \text{ V}}{V_M \times \sqrt{2} - 10 \text{ V}}$$

$V_{R(\text{peak})}$  is the peak voltage of the remaining phase angle, which should be high enough to generate the supply voltage,  $V_S$ .

**Figure 3-5.**  $\alpha_{\min}$  Operation (Two-wire Operation)



$C_1$	=	100 $\mu\text{F}/35\text{V}$
$C_0$	=	0.33 $\mu\text{F}/250\text{V} \sim$
$R_0$	=	390 $\Omega$
$R_{\text{sync}}$	=	220 k $\Omega$
$R_\alpha$	=	10 k $\Omega$
$R_G$	=	390 $\Omega$
$D_1$	=	IN 4007

### 3.5 Tracking Time Pin 7

An internal RC oscillator with a following divider stage  $1:2^{10}$  allows a very long and reproducible tracking time.

The RC values for the required final time,  $t_t$ , can be calculated as follows:

$$R_t[\Omega] = \frac{t_t[s] \times 10^6}{1.6 \times 1024 \times C_t[\mu F]}$$

$$C_t[\mu F] = \frac{t_t[s] \times 10^6}{1.6 \times 1024 \times R_t[\Omega]}$$

$$t_t[s] = \frac{C_t[\mu F] \times R_t[\Omega] \times 1.6 \times 1024}{10^6}$$

### 3.6 Trigger Inputs Pins 5 and 6

Two AND-connected, identical inputs determine the trigger conditions of the monostable time stages (Figure 3-6, Figure 3-7 on page 9), i.e., both inputs must be in position “ON” so that the output is switched on. The tracking time starts after the trigger conditions have elapsed. The output ON state is given until the tracking time has elapsed.

Input pin 5 is a simple comparator, whereas input pin 6 is designed as a window discriminator.

The noise suppression for  $t_{ON} = 40$  ms prevents peak noise signals at the inputs which could trigger the circuit.

At the same time, the retrigger function is delayed for a duration of 640 ms ( $t_{OFF}$ ) to avoid noise signal that may trigger the relay.

**Figure 3-6.** Trigger Condition, Pin 5

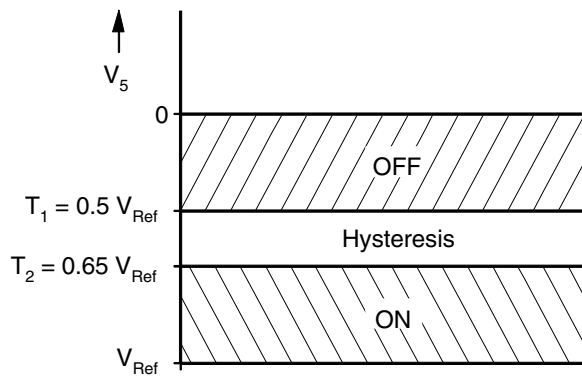
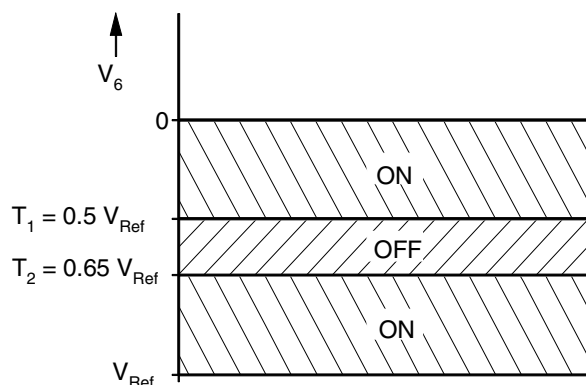




Figure 3-7. Trigger Condition, Pin 6



## 4. Absolute Maximum Ratings

Stresses beyond those listed under “Absolute Maximum Ratings” may cause permanent damage to the device. This is a stress rating only and functional operation of the device at these or any other conditions beyond those indicated in the operational sections of this specification is not implied. Exposure to absolute maximum rating conditions for extended periods may affect device reliability.

Parameters	Pin	Symbol	Value	Unit
<b>Supply</b>				
2				
Supply current		$-I_S$	10	mA
Peak current $t \leq 10$ ms		$-i_s$	60	mA
Supply voltage		$-V_S$	32	V
Reference voltage source Output current	8	$I_O$	3	mA
Synchronization Input current $t \leq 10$ ms	4	$\pm I_{Sync.}$ $i_{Sync.}$	5 20	mA mA
<b>Window Monitoring</b>				
Input voltage	6	$-V_1$	$V_{Ref}$ to 0	V
<b>Enable Schmitt Trigger</b>				
5				
Input voltage		$-V_1$	$V_{Ref}$ to 0	V
<b>Driver Output</b>				
3				
Collector voltage		$-V_o$	$V_S$ to 2	V
Storage temperature range		$T_{stg}$	-40 to +125	°C
Junction temperature		$T_j$	125	°C
Ambient temperature range		$T_{amb}$	0 to 100	°C

## 5. Thermal Resistance

Parameters		Symbol	Value	Unit
Junction ambient	DIP8	$R_{thJA}$	110	K/W
	SO8 on PC board	$R_{thJA}$	220	K/W
	SO8 on ceramic	$R_{thJA}$	140	K/W

## 6. Electrical Characteristics

$V_S = -18V$ ,  $T_{amb} = 25^\circ C$ , reference point pin 1, unless otherwise specified.

Parameters	Test Conditions	Pin	Symbol	Min.	Typ.	Max.	Unit
Supply-voltage limitation	$I_S = 800 \mu A$ $I_S = 2 mA$	2	$-V_S$	21		23	V
			$-V_S$	21.3		24	V
Current consumption	$I_3 = 0$		$-I_S$			750	$\mu A$
<b>Supply-voltage Monitoring</b>		2					
ON-threshold			$-V_S$		15		V
OFF-threshold			$-V_S$		6.5		V
Reference voltage	$I_8 = 0.1 mA$ $I_8 = 1.5 mA$	8	$-V_{Ref}$	4.95		5.45	V
			$-V_{Ref}$	4.75		5.45	V
Synchronization		4					
Input current			$\pm i_{sync}$	0.1		1.1	mA
Voltage limitation	$I_4 = \pm 1 mA$		$\pm V_{sync}$	8.8	9.4	10	V
Remaining phase angle $\alpha_{min}$ threshold	ON		$\pm V_T$	3.6	4	4.4	V
	Off		$\pm V_T$	1.8	2	2.2	V
Zero identification		4					
Zero identification	ON		$\pm V_T$		1.5		V
	OFF		$\pm I_T$		8.5		$\mu A$
			$\pm V_T$		4		V
			$\pm I_T$		20		$\mu A$
Operation Selection		4					
Zero voltage switch			$\pm V_{sync}$		$V_4$ limit		
$\alpha_{min}$ operation			$+V_{sync}$		$V_4$ limit		V
			$-V_{sync}$		6.5 to 7.8		V
DC mode			$-V_{sync}$		$V_4$ limit		V
			$+V_{sync}$		6.5 to 7.8		V
Window Monitoring, <a href="#">Figure 3-7 on page 9</a>		6					
Threshold 1			$-V_I/V_{Ref}$	0.52	0.49	0.46	
Threshold 2			$-V_I/V_{Ref}$	0.67	0.65	0.63	
Enable Schmitt Trigger, <a href="#">Figure 3-6 on page 8</a>		5					
Threshold 1	OFF		$-V_I/V_{Ref}$	0.33	0.3	0.27	
Threshold 2	ON		$-V_I/V_{Ref}$	0.62	0.6	0.58	
Oscillator	$f = \frac{1}{1.6 \times R_t \times C_t}$	5					
Threshold 1	7 - 1		$V_I/V_{Ref}$	0.25	0.20	0.15	
Threshold 2	7 - 8		$V_I$		100	200	mV
Input current	7		$I_I$		100	500	nA
Output Stage		3					
Saturation voltage	$I_3 = 100 mA$		$V_{3-2}$			2	V
Output current			$I_3$	100			mA

## 7. Applications

Figure 7-1. Lamp Time Control 18 Seconds to 23 Minutes for Two-wire Systems

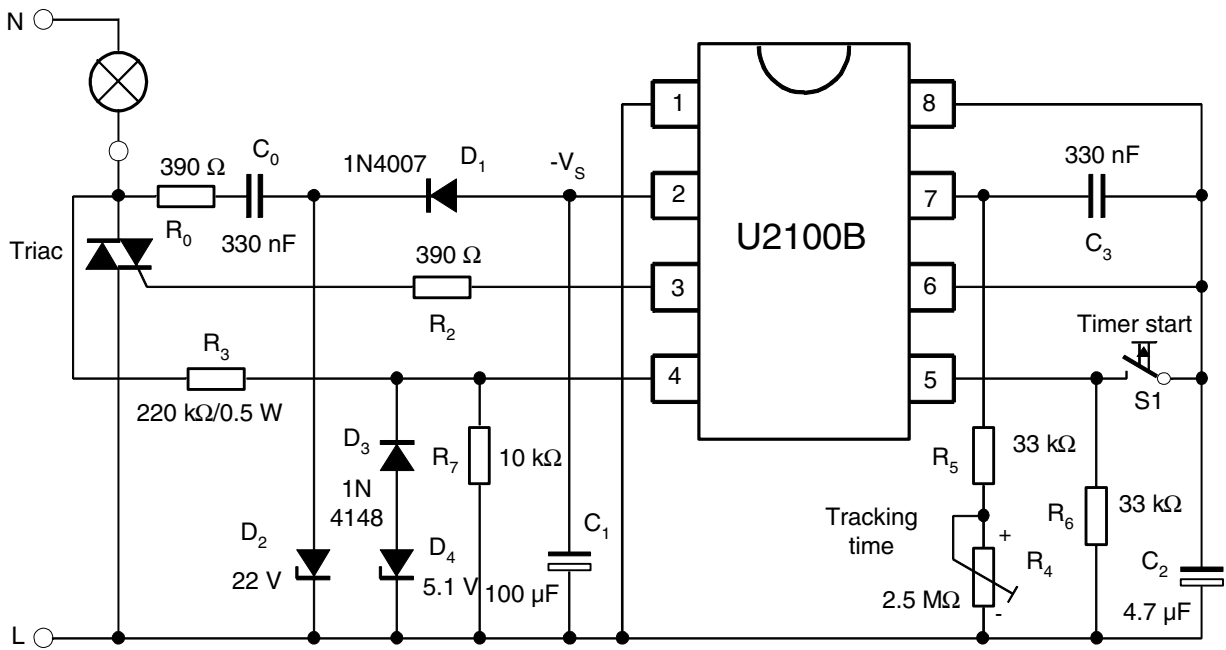
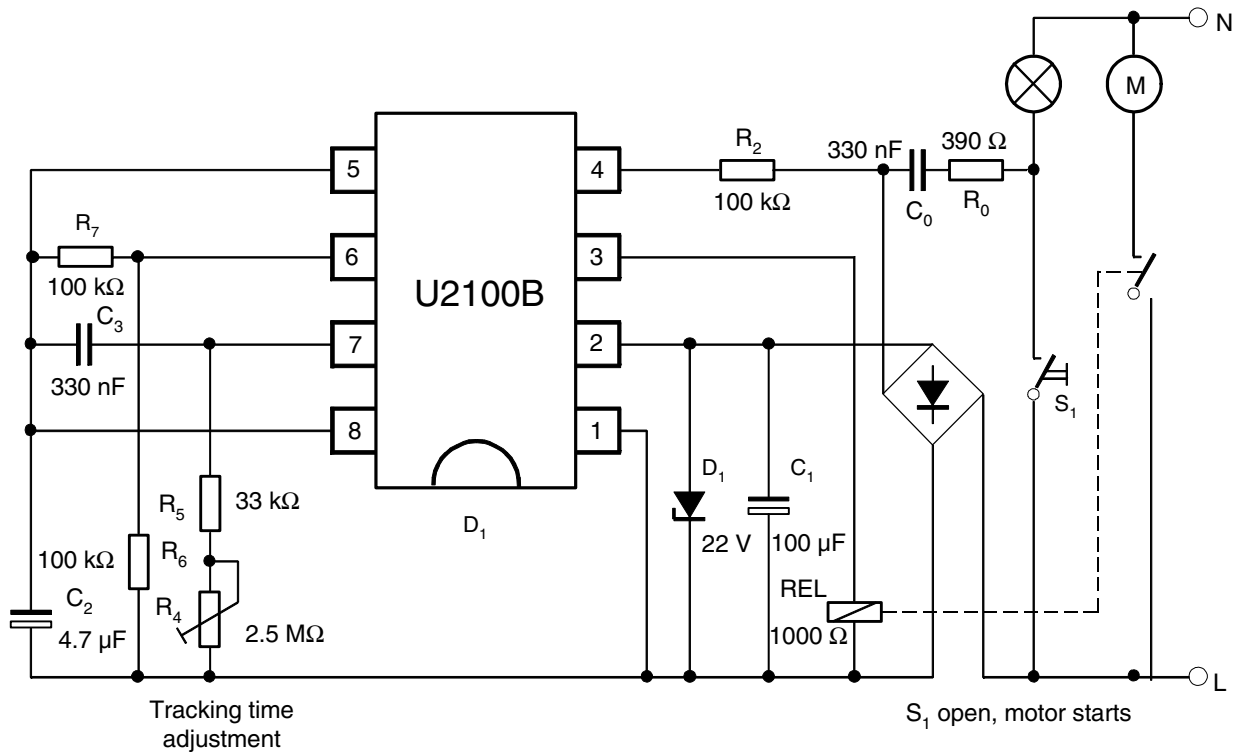


Figure 7-2. Fan Tracking Time Control 18 Seconds to 23 Minutes



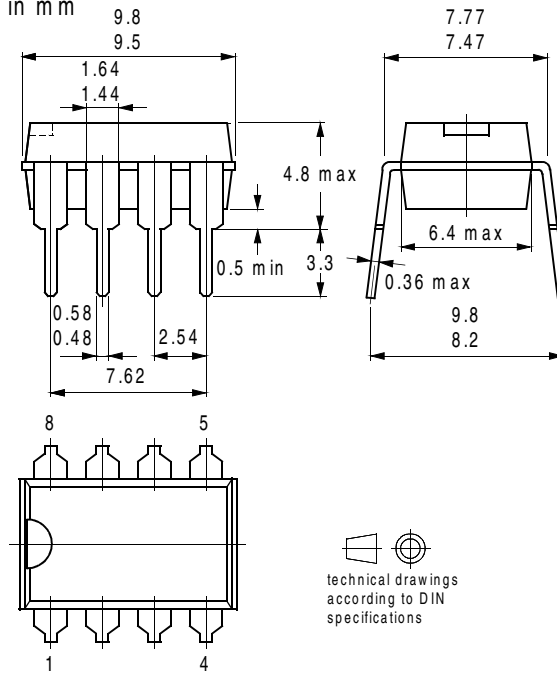
## 8. Ordering Information

Extended Type Number	Package	Remarks
U2100B-xY	DIP8	Tube
U2100B-xFPY	SO8	Tube
U2100B-xFPG3Y	SO8	Taped and reeled

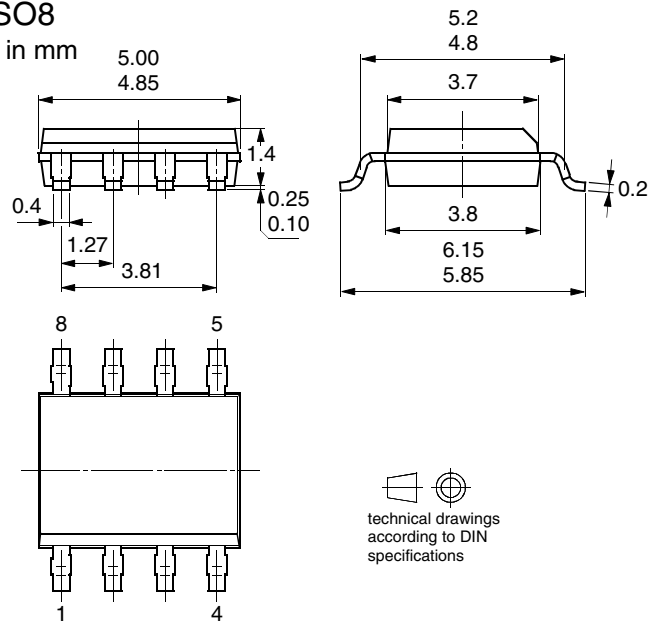
## 9. Package Information

### Package DIP8

Dimensions in mm



Package SO8  
Dimensions in mm



## 10. Revision History

Please note that the following page numbers referred to in this section refer to the specific revision mentioned, not to this document.

Revision No.	History
4769C-INDCO-07/05	<ul style="list-style-type: none"> <li>Put datasheet in a new template</li> <li>Section 3.5 "Tracking Time Pin 7" on page 8 changed</li> </ul>
4769B-INDCO-12/04	<ul style="list-style-type: none"> <li>Put datasheet in a new template</li> <li>Table "Electrical Characteristics" on page 9 changed</li> </ul>



## Atmel Corporation

2325 Orchard Parkway  
San Jose, CA 95131, USA  
Tel: 1(408) 441-0311  
Fax: 1(408) 487-2600

## Regional Headquarters

### Europe

Atmel Sarl  
Route des Arsenaux 41  
Case Postale 80  
CH-1705 Fribourg  
Switzerland  
Tel: (41) 26-426-5555  
Fax: (41) 26-426-5500

### Asia

Room 1219  
Chinachem Golden Plaza  
77 Mody Road Tsimshatsui  
East Kowloon  
Hong Kong  
Tel: (852) 2721-9778  
Fax: (852) 2722-1369

### Japan

9F, Tonetsu Shinkawa Bldg.  
1-24-8 Shinkawa  
Chuo-ku, Tokyo 104-0033  
Japan  
Tel: (81) 3-3523-3551  
Fax: (81) 3-3523-7581

## Atmel Operations

### Memory

2325 Orchard Parkway  
San Jose, CA 95131, USA  
Tel: 1(408) 441-0311  
Fax: 1(408) 436-4314

### Microcontrollers

2325 Orchard Parkway  
San Jose, CA 95131, USA  
Tel: 1(408) 441-0311  
Fax: 1(408) 436-4314

La Chantrerie  
BP 70602  
44306 Nantes Cedex 3, France  
Tel: (33) 2-40-18-18-18  
Fax: (33) 2-40-18-19-60

### ASIC/ASSP/Smart Cards

Zone Industrielle  
13106 Rousset Cedex, France  
Tel: (33) 4-42-53-60-00  
Fax: (33) 4-42-53-60-01

1150 East Cheyenne Mtn. Blvd.  
Colorado Springs, CO 80906, USA  
Tel: 1(719) 576-3300  
Fax: 1(719) 540-1759

Scottish Enterprise Technology Park  
Maxwell Building  
East Kilbride G75 0QR, Scotland  
Tel: (44) 1355-803-000  
Fax: (44) 1355-242-743

### RF/Automotive

Theresienstrasse 2  
Postfach 3535  
74025 Heilbronn, Germany  
Tel: (49) 71-31-67-0  
Fax: (49) 71-31-67-2340

1150 East Cheyenne Mtn. Blvd.  
Colorado Springs, CO 80906, USA  
Tel: 1(719) 576-3300  
Fax: 1(719) 540-1759

### Biometrics/Imaging/Hi-Rel MPU/ High Speed Converters/RF Datacom

Avenue de Rochepleine  
BP 123  
38521 Saint-Egreve Cedex, France  
Tel: (33) 4-76-58-30-00  
Fax: (33) 4-76-58-34-80

---

### Literature Requests

[www.atmel.com/literature](http://www.atmel.com/literature)

**Disclaimer:** The information in this document is provided in connection with Atmel products. No license, express or implied, by estoppel or otherwise, to any intellectual property right is granted by this document or in connection with the sale of Atmel products. **EXCEPT AS SET FORTH IN ATMEL'S TERMS AND CONDITIONS OF SALE LOCATED ON ATMEL'S WEB SITE, ATMEL ASSUMES NO LIABILITY WHATSOEVER AND DISCLAIMS ANY EXPRESS, IMPLIED OR STATUTORY WARRANTY RELATING TO ITS PRODUCTS INCLUDING, BUT NOT LIMITED TO, THE IMPLIED WARRANTY OF MERCHANTABILITY, FITNESS FOR A PARTICULAR PURPOSE, OR NON-INFRINGEMENT. IN NO EVENT SHALL ATMEL BE LIABLE FOR ANY DIRECT, INDIRECT, CONSEQUENTIAL, PUNITIVE, SPECIAL OR INCIDENTAL DAMAGES (INCLUDING, WITHOUT LIMITATION, DAMAGES FOR LOSS OF PROFITS, BUSINESS INTERRUPTION, OR LOSS OF INFORMATION) ARISING OUT OF THE USE OR INABILITY TO USE THIS DOCUMENT, EVEN IF ATMEL HAS BEEN ADVISED OF THE POSSIBILITY OF SUCH DAMAGES.** Atmel makes no representations or warranties with respect to the accuracy or completeness of the contents of this document and reserves the right to make changes to specifications and product descriptions at any time without notice. Atmel does not make any commitment to update the information contained herein. Unless specifically provided otherwise, Atmel products are not suitable for, and shall not be used in, automotive applications. Atmel's products are not intended, authorized, or warranted for use as components in applications intended to support or sustain life.

© Atmel Corporation 2005. All rights reserved. Atmel®, logo and combinations thereof, Everywhere You Are® and others, are registered trademarks or trademarks of Atmel Corporation or its subsidiaries. Other terms and product names may be trademarks of others.



Printed on recycled paper.

4769C-INDCO-07/05